

Scale 1:2	Dwg type Dwg size A4P	Total weight kg					
Measures mm	Surface texture Ra (um)	General tolerance	Material weight kg	Rev.	Times	Change	Date Name
			Drawn				Dwg No. P100
			Check.				
			Appr.				
Pulttikiinnike, kiinnitysväli		Part	pcs	Job No.		Description Pulttikiinnike, kiinnitysväli 100mm	
Belongs to							
Man. Code							
OEM Code							

SECTION A-A SCALE 1 : 2

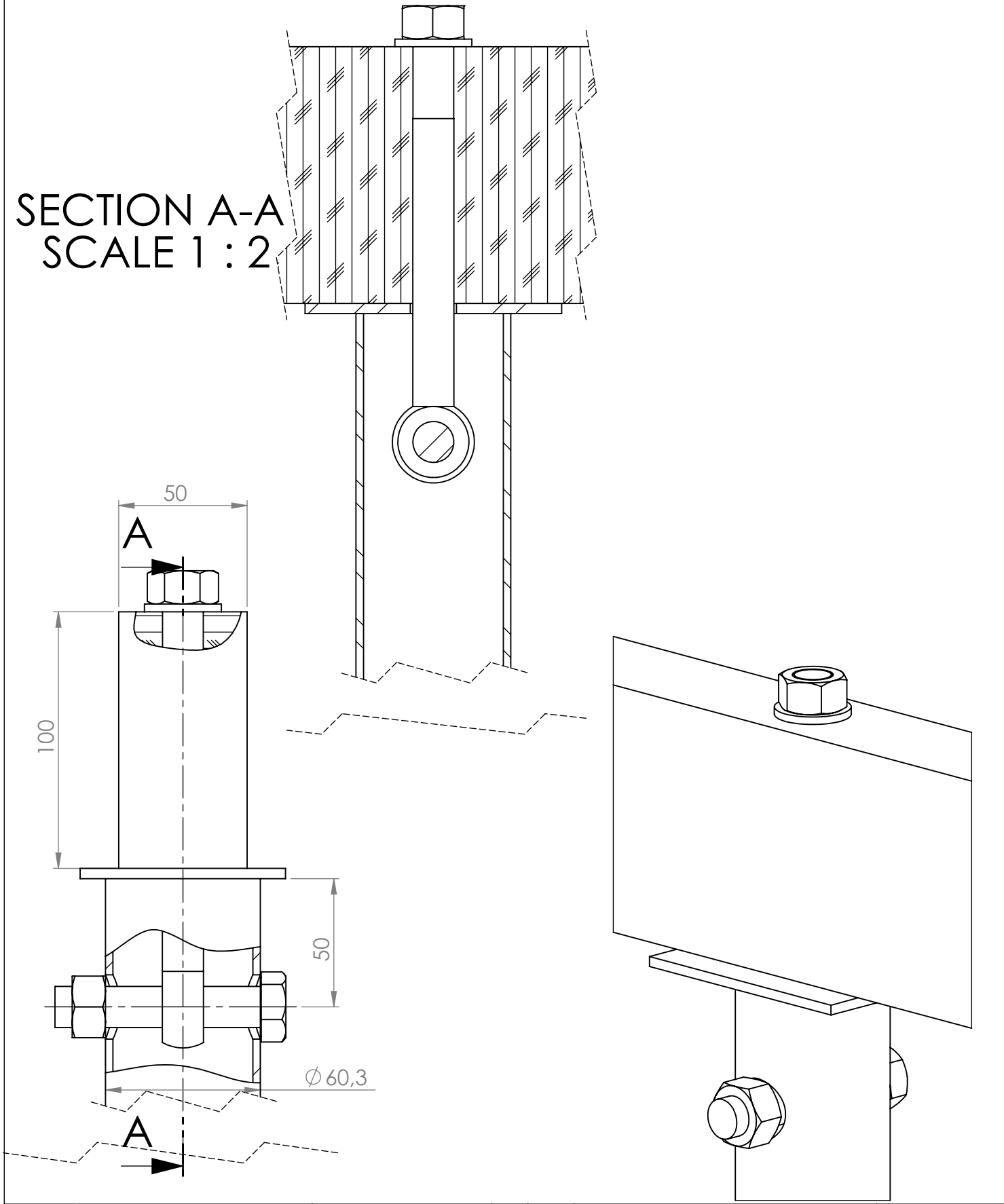

Scale 1:2	Dwg type A4P	Total weight kg					
	Dwg size	Material weight kg	Rev.	Times	Change	Date	Name
Measures mm	Surface texture Ra (um)	General tolerance	Drawn				
			Check.				
			Appr.				
Kokoonpano			Part		pcs	Job No.	Description
Belongs to							Pulttikiinnike, kiinnitysväli 100mm
Man. Code							
OEM Code							



Dwg No. P100